

Issue No.:
 Issue Date:

1
 101104

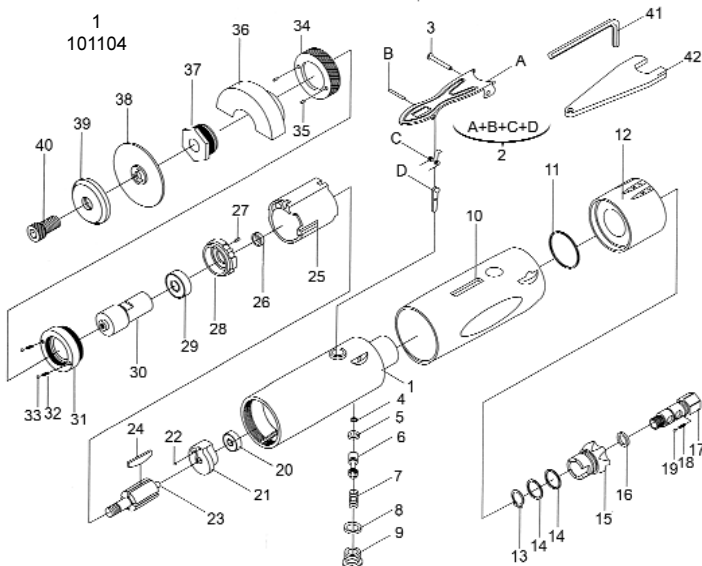

Item	Part No	Description	Item	Part No	Description	Item	Part No	Description
1.	GSA25.01	HOUSING	15.	GSA25.18	AIR REGULATOR	29.	GSA25.32	BEARING
2.	GSA25.02	TRIGGER ASS'Y	16.	GSA25.19	O-RING	30.	GSA25.33	COLLET HOLDER
3.	GSA25.03	PIN	17.	GSA25.20	AIR INLET	31.	GSA25.34	CONNECT NUT
4.	GSA25.07	O-RING	18.	GSA25.21	SPRING	32.	GSA25.35	SPRING
5.	GSA25.08	O-RING	19.	GSA25.22	TIP SLEEVE	33.	GSA25.36	STEEL BALL
6.	GSA25.09	VALVE STEM	20.	GSA25.23	BEARING	34.	GSA25.37	REGULATOR
7.	GSA25.10	SPRING	21.	GSA25.24	END PLATE	35.	GSA25.38	PIN
8.	GSA25.11	O-RING	22.	GSA25.25	STEEL BALL	36.	GSA25.39	SAFETY GUARD
9.	GSA25.12	NUT	23.	GSA25.26	ROTOR	37.	GSA25.40	NUT
10.	GSA25.13	RUBBER GRIP	24.	GSA25.27	ROTOR BLADE	38.	GSA25.41	CUTTING WHEEL
11.	GSA25.14	O-RING	25.	GSA25.28	CYLINDER	39.	GSA25.42	WASHER
12.	GSA25.15	MUFFLE COVER	26.	GSA25.29	BUSHING	40.	GSA25.43	SCREW
13.	GSA25.16	RETAINING RING	27.	GSA25.30	PIN	41.	GSA25.44	HEX KEY
14.	GSA25.17	O-RING	28.	GSA25.31	FRONT PLATE	42.	GSA25.45	WRENCH

NOTE: It is our policy to continually improve products and as such we reserve the right to alter data, specifications and component parts without prior notice. **IMPORTANT:** No liability is accepted for incorrect use of this equipment. **WARRANTY:** Guarantee is 12 months from purchase date, proof of which will be required for any claim. **INFORMATION:** For a copy of our latest catalogue and promotions call us on 01284 757525 and leave your full name and address, including postcode.

Declaration of Conformity



We, the sole importer into the UK, declare that the product listed here is in conformity with the following standards and directives. The construction file for this product is held by the Manufacturer and may be inspected, by a national authority, upon request to Jack Sealey Ltd.

Air Cut-off Tool (G3) GSA25
 98/37/EC Machinery Directive
 93/68/EEC Marking Directive

Signed by Mark Sweetman

10th November 2004

For Jack Sealey Ltd. Sole
 importer into the UK of
 Sealey Power Tools.

