

Thank you for purchasing a Sealey product. Manufactured to a high standard this product will, if used according to these instructions and properly maintained, give you years of trouble free performance.

⚠ IMPORTANT: PLEASE READ THESE INSTRUCTIONS CAREFULLY. NOTE THE SAFE OPERATIONAL REQUIREMENTS, WARNINGS & CAUTIONS. USE THE PRODUCT CORRECTLY AND WITH CARE FOR THE PURPOSE FOR WHICH IT IS INTENDED. FAILURE TO DO SO MAY CAUSE DAMAGE AND/OR PERSONAL INJURY AND WILL INVALIDATE THE WARRANTY. PLEASE KEEP INSTRUCTIONS SAFE FOR FUTURE USE.

1. SAFETY INSTRUCTIONS

1.1. ELECTRICAL SAFETY

⚠ WARNING! It is the responsibility of the owner and the operator to read, understand and comply with the following:
 You must check all electrical products, before use, to ensure that they are safe. You must inspect power cables, plugs, sockets and any other connectors for wear or damage. You must ensure that the risk of electric shock is minimised by the installation of appropriate safety devices. A Residual Current Circuit Breaker (RCCB) should be incorporated in the main distribution board. We also recommend that a Residual Current Device (RCD) is used. It is particularly important to use an RCD with portable products that are plugged into a supply which is not protected by an RCCB. If in any doubt consult a qualified electrician. You may obtain a Residual Current Device by contacting your Sealey dealer. You must also read and understand the following instructions concerning electrical safety.

- 1.1.1. The **Electricity at Work Act 1989** requires that all portable electrical appliances, if used on business premises, are tested by a qualified electrician, using a Portable Appliance Tester (PAT), at least once a year.
 - 1.1.2. The **Health & Safety at Work Act 1974** makes owners of electrical appliances responsible for the safe condition of those appliances and the safety of the appliance operators. If in any doubt about electrical safety, contact a qualified electrician.
 - 1.1.3. Ensure that the insulation on all cables and on the appliance is safe before connecting it to the power supply. See 1.1.1. and 1.1.2. and use a Portable Appliance Tester.
 - 1.1.4. Ensure that cables are always protected against short circuit and overload.
 - 1.1.5. Regularly inspect power supply cables and plugs for wear or damage and check all connections to ensure that none is loose.
 - 1.1.6. **Important:** Ensure that the voltage marked on the appliance matches the power supply to be used and that the plug is fitted with the correct fuse - see fuse rating at right.
 - 1.1.7. **DO NOT** pull or carry the appliance by the power cable.
 - 1.1.8. **DO NOT** pull the plug from the socket by the cable.
 - 1.1.9. **DO NOT** use worn or damaged cables, plugs or connectors. Immediately have any faulty item repaired or replaced by a qualified electrician. When a BS 1363/A UK 3 pin plug is damaged, cut the cable just above the plug and **dispose of the plug safely**. Fit a new plug according to the following instructions (UK only).
 - a) Connect the **GREEN/YELLOW earth wire to the earth terminal 'E'**.
 - b) Connect the **BROWN live wire to the live terminal 'L'**.
 - c) Connect the **BLUE neutral wire to the neutral terminal 'N'**.
 - d) **After wiring, check that there are no bare wires, that all wires have been correctly connected, that the cable outer insulation extends beyond the cable restraint and that the restraint is tight.**
- Double insulated products, which are always marked with this symbol , are fitted with live (brown) and neutral (blue) wires only. To rewire, connect the wires as indicated above - **DO NOT** connect either wire to the earth terminal.
- 1.1.10. Products which require more than 13amps are supplied without a plug. In this case you must contact a qualified electrician to ensure that a suitably rated supply is available. We recommend that you discuss the installation of an industrial round pin plug and socket with your electrician.
 - 1.1.11. If an extension reel is used it should be fully unwound before connection. A reel with an RCD fitted is preferred since any appliance plugged into it will be protected. The cable core section is important and should be at least 1.5mm², but to be absolutely sure that the capacity of the reel is suitable for this product and for others which may be used in the other output sockets, we recommend the use of 2.5mm² section cable.

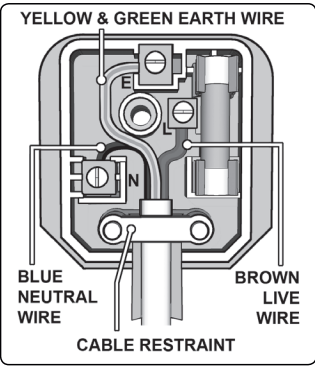

RECOMMENDED FUSE RATING: 13AMP

1.2. GENERAL SAFETY

- WARNING!** Ensure all Health and Safety, local authority, and general workshop practice regulations are strictly adhered to.
- WARNING!** Disconnect from the mains power supply before changing accessories, servicing or performing any maintenance.
- WARNING! DO NOT** sand any materials containing asbestos.
- ✓ Ensure the operating voltage stated on the ratings plate corresponds to your mains power supply.
- ✓ Check the belt and disc sander and the electrical connections for any damage and **DO NOT** use the tool if the sander or the cable is damaged.
- ✓ Ensure that the belt and disc sander is switched off before plugging in to the mains power supply.
- ✓ Persons with limited physical, sensory or mental abilities are not allowed to use the unit, unless they are fully supervised and briefed on safety issues by a qualified person.
- ✓ Use the belt and disc sander according to this manual and only for the purpose for which it is designed.
- ✓ Before starting up, make sure that no spanners or adjusting keys are attached to the machine.
- ✓ Avoid contact with grounded surfaces such as radiators, pipes etc.
- ✓ Maintain correct balance and footing, ensure that the floor is not slippery and wear non-slip rubber soled footwear.
- ✓ **NOTE:** Remember that the disc and belt will still be moving for several seconds whilst slowing down, **after** switching off.
- ✓ Familiarise yourself with your working area and be alert for possible hazards, which you might not hear due to machine noise.
- ✓ Inspect the work piece and remove all nails and screws before sanding.
- ✓ Be aware that sparks may ignite the dust or fumes.
- ✓ Switch off the belt and disc sander before making any adjustments and when the unit is not in use.
- ✓ After finishing work and before carrying out maintenance, disconnect the power lead from the mains supply.
- ✓ In the event of an electrical or mechanical malfunction, immediately switch off the sander and **DO NOT** use it further.
- ✓ Always keep your work area clean.
- ✓ Never use the power cable to carry the belt and disc sander. Keep the cable away from hot, sharp edges and moving parts.
- WARNING!** Always wear gloves and safety goggles and a dust mask as some coatings and wood dust may be harmful and toxic.

- ✓ Always work in a well ventilated area. Whenever possible use the dust collection outlets provided on the machine.
- ✓ Take care that the belt and disc sander cannot tip over or move while sanding long or heavy objects. If necessary, fasten the belt and disc sander to a supporting surface.
- ✓ Ensure that the sanding belt is running in the correct direction and ensure that the sanding disc or sanding belt is not damaged.
- ✗ **DO NOT** allow children or untrained persons to operate the sander. Keep them away from the work area.
- ✓ Ensure the sanding belt is correctly positioned and adjusted so that it cannot run off the pulleys.
- ✗ **DO NOT** remove the safety guard whilst sander is in use.
- ✓ Remove ill fitting clothing, ties and loose jewellery and tie back long hair. Keep hands and body clear of the worktable when operating the sander.
- ✗ **DO NOT** use the belt and disc sander near flammable liquids, gases or dust.
- ✗ **DO NOT** disassemble the machine and do not try to repair it yourself. Have the unit repaired by a professional or contact your local Sealey dealer. Always use original replacement parts.
- ✗ **DO NOT** touch the sanding belt immediately after operation; it may be extremely hot and cause burns. The sanding belt is sharp-edged.
- ✗ **DO NOT** use excessive force against the sanding belt or disc.
- ✗ **DO NOT** operate the sander when you are tired, under the influence of alcohol, drugs or intoxicating medication.
- ✗ **DO NOT** get the sander wet or use in damp or wet locations or areas where there is condensation.
- ✗ **DO NOT** switch the sander on while the workpiece is in contact with the abrasive and **DO NOT** leave the sander running unattended.

2. INTRODUCTION

Bench mounting semi-portable belt and disc sander suitable for general woodworking applications. Powerful induction motor with smooth, bearing-mounted drive pulleys gives quiet operation. The sanding belt can be used in a vertical or horizontal position and at any other angle inbetween. The sanding disc table can be tilted to any angle up to 45°, and is supplied with a mitre gauge for accurate angle sanding.

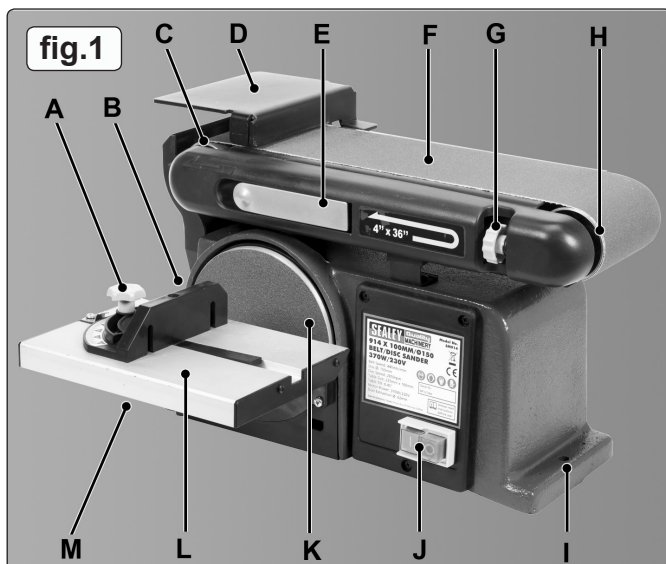

- | | |
|---|--------------------------------------|
| A MITRE GAUGE | H IDLER DRUM |
| B KNOB FOR TABLE ANGLE ADJUSTMENT (Not visible) | I MOUNTING POINT x 3 |
| C DRIVE DRUM | J ON/OFF SWITCH |
| D BELT SANDING GUARD | K SANDING DISC |
| E BELT TENSIONING LEVER | L DISC SANDING TABLE |
| F SANDING BELT | M DUST EXTRACTION PORT (Not visible) |
| G BELT TRACKING CONTROL | |

3. TECHNICAL SPECIFICATION

Model No:	SM914
Belt Size:915 x 100mm
Belt Speed:	440mtr/min
Disc Size:	Ø150mm
Disc Speed:	2850rpm
Table Size:	230 x 160mm
Table Tilt:	0-45°
Motor Power:	370W
Supply:	230V
Dust Extraction:	Ø62mm
Weight:	18.5kg

Replacement Sanding Belts:	
Model No:	Grade:
SM14/B060G	60Grit
SM14/B080G	80Grit
SM14/B100G	100Grit
Replacement Sanding Discs:	
Model No:	Grade:
SM14/D80G	80Grit

4. ASSEMBLY & ADJUSTMENT

4.1 Mounting the sander.

- 4.1.1 Mount the sander to a suitable workbench adjacent to dust extraction facilities if available. Bolt the sander down utilising the three mounting holes, two in the left hand flange and one on the right hand flange. Insert bolts from above and fasten below with nuts and lock washers.

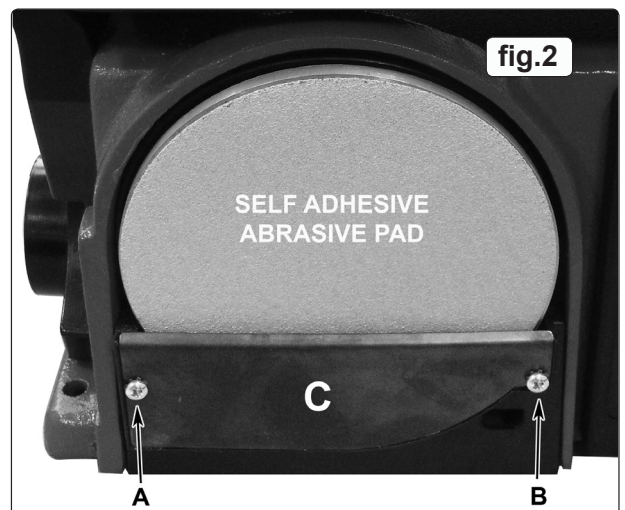

WARNING! Ensure that the sander is disconnected from the mains power supply before beginning assembly.

4.2 Attaching the sanding disc abrasive pad and lower cover.

- 4.2.1 Before attaching cover (C) in place, remove the backing from the self adhesive abrasive pad and stick it to the metal disc ensuring that it is centralised. Fix the lower cover (C) in place as shown above using two self tapping screws (A&B).

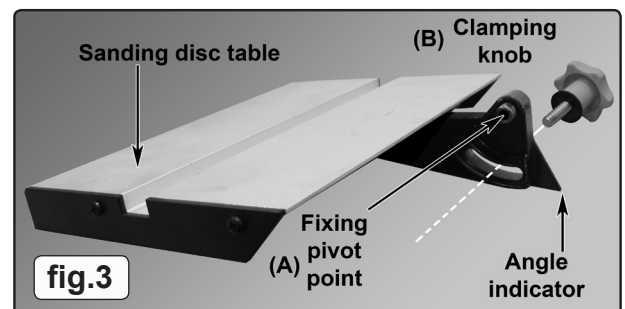

4.3 Attaching the sanding disc table.

- 4.3.1 The sanding disc table has one pivot/fixing point as indicated above which plugs directly into the main body of the sander and is held in place by a single clamping knob as shown in fig.4.

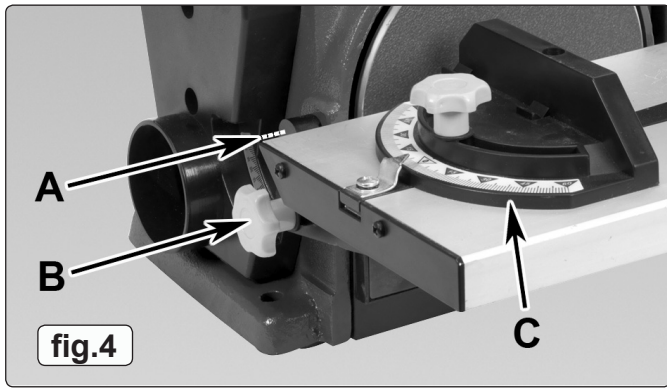

4.3.2 Fig.4 shows the sanding table in place, pivoting around point (A) and held in place by clamping knob (B). Place the mitre guide (C) into the slot in the table when required.

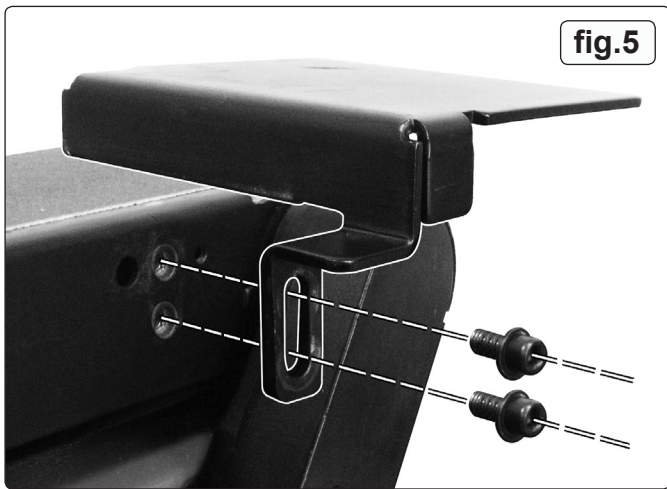

4.4 Attaching the sanding belt work support/guard.

4.4.1 Referring to fig.5 above, position the slotted mounting leg of the work support/guard over the two threaded holes in the side of the belt housing and fix in place using the two socket cap screws and washers provided. Screw them down, finger tight only at this stage. Supporting the underside of the work support/guard, lift it slightly so that there is at least 1.5mm of clearance between the support and the surface of the belt and then fully tighten the bolts using a 6mm hex key.

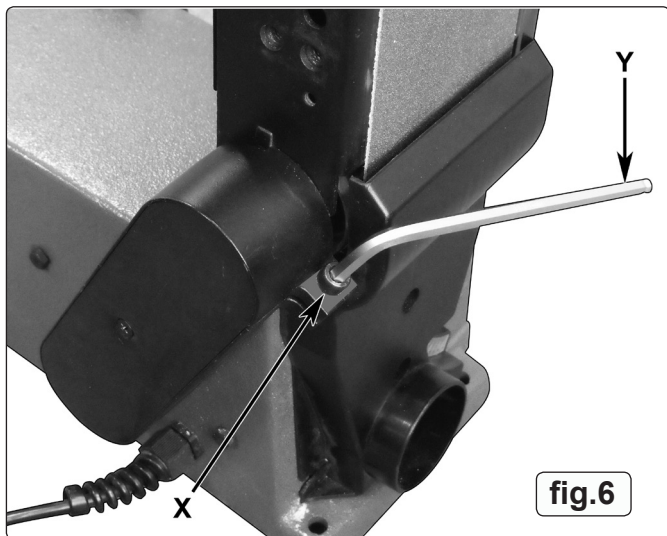

4.5 Changing the sanding belt orientation. (See fig.6)

4.5.1 The sanding belt can be used either horizontally, vertically or at any angle inbetween, but must be locked in the chosen position using the clamping nut (X) situated to one side of the drive drum.
4.5.2 To change from the horizontal to the vertical position it is advisable to remove the work support to give easier access to the clamping nut.

4.5.3 Firstly, loosen the clamping nut with a 6mm hex key (Y).
4.5.4 Lift the belt assembly into the vertical position (or any angle inbetween) and fully re-tighten the clamping nut.
4.5.5 Re-attach the work support table/guard and fully tighten the two fixing screws ensuring that there is at least 1.5mm clearance between the guard and the surface of the belt.
4.5.6 To return to the horizontal position, reverse the process just described.
WARNING! Never use the sanding belt without the work support/guard attached.

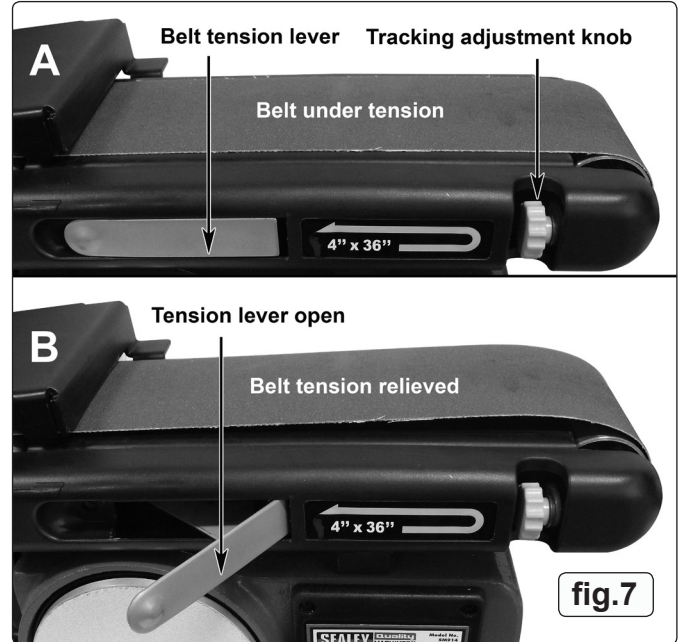

4.6 Belt tracking control (minor adjustment). (See fig.7A)

4.6.1 The sanding belt tracking is factory set so that the belt will run true on the rollers. If however the belt should begin to deviate from true it can be corrected using the tracking adjustment control knob seen in fig.7A. Turning the knob clockwise will cause the belt to move towards the front of the machine (i.e. the disc side). Turning the knob counter clockwise will cause the belt to move towards the back of the machine.



4.7 Changing the sanding belt.

- 4.7.1 Before the sanding belt can be changed, the protective cover on the back/underside of the belt assembly must be removed.
 - 4.7.2 Move the belt assembly into the vertical position as described in Section 4 and loosen the two screws indicated in fig.8.
 - 4.7.3 Unhook the cover from the sanding belt assembly by lifting it up and away from the sander. Put to one side.
 - 4.7.4 Release the tension from the belt by pulling open the tensioning lever as indicated in fig.7B.
 - 4.7.5 Slide the old belt off the rollers. Slide the new belt into position on the rollers and re-tension it as described below.
 - 4.7.6 Take hold of the belt tensioning lever and ease it back into position taking care not to trap your fingers behind the lever.
- WARNING!** In the open position the lever is spring loaded and will snap shut if pushed.

4.8 Tracking adjustment of new belt. (See fig.7A)

- 4.8.1 When a new belt is fitted the full tracking procedure should be followed.
- 4.8.2 To check if the belt is tracking correctly, turn the sander on and off again immediately and note how the belt is running. If the belt runs true on its rollers with no deviation, no tracking adjustment is required.
- 4.8.3 If however the belt should begin to deviate from true it can be corrected using the tracking adjustment control knob seen in fig.7A. Turning the knob clockwise by a ¼ turn will cause the belt to move towards the front of the machine (i.e. the disc side). Turning the knob counter clockwise by a ¼ turn will cause the belt to move towards the back of the machine.

4.9 Dust extraction port. (See fig.1M)

- 4.9.1 Where available the sander should always be connected to a dust extraction system via the Ø62mm port provided on the left hand side of the machine. It is also recommended that the operator should still wear respiratory protection as a dust extraction system cannot eliminate all dust produced during the sanding process.

5. OPERATING INSTRUCTIONS

- WARNING! DO NOT** allow two people to use the sander at the same time. **Remember that even though you are using only one of the sanding facilities, the other is still turning and could represent a hazard to you or other people nearby.**

5.1 Using the sanding disc.

- 5.1.1 Ensure that the work support table is correctly fixed to the sander. Adjust the angle of the table and/or mitre guide as required by the job in hand.
- 5.1.2 Plug the sander into the mains power supply.
- 5.1.3 Switch on the sander using the green ON button. See fig.1(J).
- 5.1.4 Allow the disc to reach full speed before bringing the workpiece into contact with it. Hold the workpiece firmly down on the table. Always work left of centre on the disc so that the movement of the disc tends to force the workpiece down onto the table. Do not use excessive force to remove material but allow the abrasive disc to do its job.
- 5.1.5 Switch off the sander using the red OFF button. See fig.1(J).
- 5.1.6 Allow the disc and belt to come to a standstill before leaving the sander.
- 5.1.7 **DO NOT** leave the sander running unattended.

- 5.1.8 Unplug the sander from the mains power supply when no longer required.

5.2 Using the sanding belt.

- 5.2.1 Ensure that the sanding belt support/guard is correctly fixed to the sander. See section 4.4.
- 5.2.2 Move the belt assembly to the vertical or horizontal position (or any angle inbetween) as described in Section 4.5 and ensure that it is locked in position.
- 5.2.3 Plug the sander into the mains power supply.
- 5.2.4 Switch on the sander using the green ON button. See fig.1(J).
- 5.2.5 Allow the belt to reach full speed before bringing the workpiece into contact with it, close to the support/guard. (The belt moves left to right and will force the workpiece up against the support).

5.3 Broad surface sanding.

- 5.3.1 When sanding broad flat surfaces hold the workpiece with a firm grip and bring it lightly down onto the moving belt. Apply only enough pressure to allow the sanding belt to remove material.
- 5.3.2 Keep fingers away from the sanding belt, especially when sanding thin workpieces. Consider using a specially made pushing or holding down stick.
- 5.3.3 Switch off the sander using the red OFF button. See fig.1(J).
- 5.3.4 Allow the disc and belt to come to a standstill before leaving the sander.

5.4 Sanding inside-curves.

- 5.4.1 When sanding inside-curves, always use the right hand end of the sanding belt, holding the workpiece firmly and keeping fingers away from the belt.
- 5.4.2 Keep the curve pressed firmly against the idler drum and move the workpiece evenly back and forth across the drum. Only apply enough pressure to allow the belt to remove material gradually.
- 5.4.3 Switch off the sander using the red OFF button. See fig.1(J).
- 5.4.4 Allow the disc and belt to come to a standstill before leaving the sander.
- 5.4.5 **DO NOT** leave the sander running unattended.
- 5.4.6 Unplug the sander from the mains power supply when no longer required.

6. MAINTENANCE

- WARNING!** Disconnect from the mains power supply before changing accessories, servicing or performing any maintenance.

6.1 General Maintenance.

- 6.1.1 Before each use check the condition of the power cable for wear or damage.
- 6.1.2 Before each use check the sanding disc and belt for wear or damage.
- 6.1.3 Before each use check moving parts for alignment or binding issues.
- 6.1.4 Clean and vacuum dust from the motor housing and other sander parts on a regular basis.
- 6.1.5 Changing the sanding disc. Refer to Section 4.2.
- 6.1.6 Changing the sanding belt. Refer to Section 4.7.
- 6.1.7 For all other maintenance issues refer to your local Sealey Dealer.

Environmental Protection.



Recycle unwanted materials instead of disposing of them as waste. All tools, accessories and packaging should be sorted, taken to a recycle centre and disposed of in a manner which is compatible with the environment.



WEEE REGULATIONS. Dispose of this product at the end of its working life in compliance with the EU Directive on Waste Electrical and Electronic Equipment. When the product is no longer required, it must be disposed of in an environmentally protective way.

Parts support is available for this product. To obtain a parts listing and/or diagram, please log on to www.sealey.co.uk, email sales@sealey.co.uk or phone 01284 757500.

NOTE: It is our policy to continually improve products and as such we reserve the right to alter data, specifications and component parts without prior notice.

IMPORTANT: No liability is accepted for incorrect use of this product.

WARRANTY: Guarantee is 12 months from purchase date, proof of which will be required for any claim.

INFORMATION: For a copy of our latest catalogue and promotions call us on 01284 757525 and leave your full name and address, including postcode.



Sole UK Distributor, Sealey Group,
Kempson Way, Suffolk Business Park,
Bury St. Edmunds, Suffolk,
IP32 7AR



01284 757500



www.sealey.co.uk



01284 703534



sales@sealey.co.uk

7. MAINTENANCE

PROBLEM	CAUSE	SOLUTION
Sanding Grains easily rub off belt or discs.	1. Sanding belt/disc has been stored in an incorrect environment.	1. Ensure sanding accessories are stored away from extremely hot or dry temperatures.
	2. Sanding belt/disc has been damaged or folded.	2. Store sanding accessories flat – not bent or folded.
Deep sanding grooves or scars in workpiece.	1. Sanding belt/disc grit is too coarse for the desired finish.	1. Use a finer-grit sanding accessory.
	2. Workpiece sanded across the grain.	2. Sand with the grain of the wood.
	3. Too much sanding force on the workpiece.	3. Reduce pressure on workpiece while sanding.
	4. Workpiece held still against the belt-disc for too long.	4. Keep workpiece moving while sanding on the sanding accessory.
Sanding surface clogs quickly.	1. Too much pressure against belt/disc.	1. Reduce pressure on workpiece while sanding.
	2. Sanding softwood.	2. Use different stock, different sanding accessories, or accept that this will happen and plan on cleaning or replacing belts/discs frequently.
Burns on workpiece.	1. Using a sanding grit that is too fine.	1. Use a coarser-grit sanding accessory.
	2. Using too much pressure.	2. Reduce pressure on workpiece while sanding.
	3. Work held still for too long.	3. Do not keep workpiece in one place for too long.
Motor will not start.	1. Low voltage.	1. Check power source for proper voltage.
	2. Open circuit in motor or loose connections.	2. Inspect all lead connections on motor for loose or open connections. (Contact service agent)
	3. Blown fuse or breaker.	2. Short circuit. (Contact service agent)
		4. Improper match between tool and circuit, fuse or breaker.
Motor will not start – fuses or circuit breakers tripping or blowing.	1. Short circuit in line, cord or plug.	1. Inspect cord or plug for damaged insulation and shorted wires.
	2. Short circuit in motor or loose connections.	2. Inspect all connections on motor for loose or shorted terminals and/or worn insulation.
	3. Incorrect fuses or circuit breakers in power line.	3. Install correct fuses or circuit breakers or switch tool to an appropriately sized circuit.
Motor overheats.	1. Motor overloaded.	1. Reduce load on motor (pressure on object being sanded).
	2. Extension cord too long and of insufficient gauge (weight).	2. Utilize an extension cord of appropriate gauge and length or plug tool directly into outlet.
Motor stalls (resulting in blown fuses or tripped circuit).	1. Short circuit in motor or loose connections.	1. Inspect connections on motor for loose or shorted terminals or worn insulations. (Contact service agent)
	2. Low voltage.	2. Correct low voltage conditions (for example: improper extension cord length and/or gauge).
	3. Incorrect fuses or circuit breakers in power line.	3. Install correct fuses or circuit breakers or plug tool into an appropriate circuit, matched to an appropriate fuse or breaker.
	4. Excessive sanding pressure overloads motor.	4. Reduce the load on the motor.
Machine slows when operating.	1. Feed rate too great.	1. Reduce the rate at which the workpiece is fed onto belt or disc.
	2. Undersized circuit or use of undersized extension cord.	2. Ensure circuit wires or extension cords are proper gauge, or eliminate use of extension cords.
Machine vibrates excessively.	1. Incorrect motor mounting.	1. Tighten/strengthen motor mountings
	2. Incorrect sanding-belt tension.	2. Adjust tension adjustment knob. Follow belt-tensioning/tracking instructions in this manual.
	3. Weak or broken tension spring.	3. Have tension spring replaced by service technician.
	4. Idler roller is too loose.	4. Have service technician adjust idler roller.
	5. Broken/defective sanding accessories.	5. Replace sanding belt/disc.
Workpiece frequently gets pulled out of operator's hands.	1. Not supporting the workpiece against the stop.	1. Use the platen (backstop) or mitre gauge to support the workpiece.
	2. Attempting to sand (unaided) a workpiece that is too small.	2. Use another hand tool or jig to grasp or hold the workpiece.
Workpiece lifts up from the sanding disc/table.	1. Sanding on the "up" side of the wheel.	1. Sand on left hand side of sanding disc (as operator faces the disc).