

Thank you for purchasing a Sealey product. Manufactured to a high standard this product will, if used according to these instructions and properly maintained, give you years of trouble free performance.

**IMPORTANT: PLEASE READ THESE INSTRUCTIONS CAREFULLY. NOTE THE SAFE OPERATIONAL REQUIREMENTS, WARNINGS AND CAUTIONS. USE THE PRODUCT CORRECTLY AND WITH CARE FOR THE PURPOSE FOR WHICH IT IS INTENDED. FAILURE TO DO SO MAY CAUSE DAMAGE AND/OR PERSONAL INJURY AND WILL INVALIDATE THE WARRANTY. PLEASE KEEP INSTRUCTIONS SAFE FOR FUTURE USE.**

### 1. SAFETY INSTRUCTIONS

#### 1.2 GENERAL SAFETY

- ❑ **WARNING!** Ensure Health & Safety, local authority, and general workshop practice regulations are adhered to when using this equipment. Under Health and Safety Law, Employers and Self Employed Personnel have a legal duty to ensure Safe Working Conditions for all employees and personnel that may come into contact with this equipment. In particular they must carry out a specific risk and hazard assessment in the workplace to eliminate or reduce any risk found and must record, update and retain records of the results of this inspection.
- ✓ Familiarise yourself with the applications, limitations and any possible or potential hazards of the tyre changer.
- ✓ Maintain the tyre changer in good condition (use an authorised service agent).
- ✓ Replace or repair damaged parts. Use genuine parts only. Unauthorised parts may be dangerous and will invalidate the warranty.
- ❑ **WARNING!** Check regularly for damaged parts. Any part that is damaged must be repaired or replaced before the equipment is next used.
- ✓ Locate the tyre changer in a suitable work area, keep area clean and tidy and free from unrelated materials. Ensure that there is adequate lighting.
- ❑ **WARNING!** Use on a level surface, preferably concrete, to which the tyre changer must be bolted.
- ✓ Keep the tyre changer clean for best and safest performance.
- ✓ Wear approved safety eye protection (standard spectacles are not adequate).

- ✓ Keep hands and feet well clear of the bead breaker.
- ✓ Maintain correct balance and footing. Ensure the floor is not slippery and wear non-slip safety shoes.
- ✓ Remove ill fitting clothing. Remove ties, watches, rings, and other loose jewellery and contain and/or tie back long hair.
- ✓ Keep children and unauthorised persons away from the work area.
- x **DO NOT** use the tyre changer for any purpose other than that for which it is designed.
- x **DO NOT** operate the tyre changer if any parts are damaged or missing as this may cause failure and/or personal injury.
- x **DO NOT** allow untrained persons to operate the tyre changer.
- x **DO NOT** stand on the tyre changer.
- x **DO NOT** operate the tyre changer when you are tired or under the influence of alcohol, drugs or intoxicating medication.

#### MODEL TC962 ONLY

- ❑ **WARNING!** Ensure correct air pressure is maintained and not exceeded. Recommended maximum pressure 150psi (10.3 bar).
- ❑ **WARNING!** Disconnect the tyre changer from the air supply before changing accessories, servicing or performing any maintenance.
- ✓ Keep air hose away from heat, oil and sharp edges. Check air hose for wear before each use, and ensure that all connections are secure.
- x **DO NOT** yank the hose from the air supply.
- x **DO NOT** direct air from the air hose at yourself or others.
- ✓ When not in use ensure the air supply is turned off.

### 3. SPECIFICATIONS

	TC961	TC962
Max. Safe Working Pressure	N/A	150psi
Min. Wheel Diameter	203mm	203mm
Max. Wheel Diameter	460mm	460mm
Min. Wheel Depth	40mm	40mm
Max. Wheel Depth	203mm	304mm
Working Height	640mm	815mm

### 2. AIR SUPPLY - TC962 ONLY

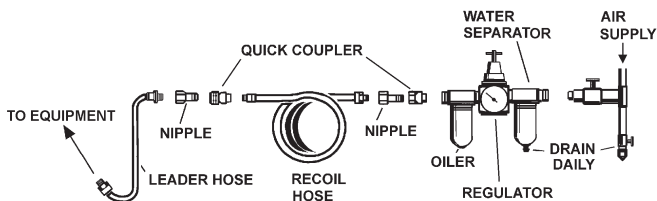

- 2.1. Ensure the air valve is in the "off" position before connecting to the air supply.
- 2.2. You will require an air pressure between 100 and 150psi.
- 2.3. ❑ **WARNING!** Ensure that the air supply is clean and does not exceed 150psi. Too high an air pressure and/or unclean air will cause excessive wear and may cause damage and/or personal injury.
- 2.4. Drain the air tank daily. Water in the air line will damage the tyre changer.
- 2.5. Clean the compressor air inlet filter screen weekly. The recommended hook-up is shown below.
- 2.6. Line pressure should be increased to compensate for unusually long air hoses (over 8 metres). The minimum hose diameter should be 10mm I.D. and fittings must have the same inside dimensions.
- 2.7. Keep hose away from heat, oil and sharp edges. Check hoses for wear and make certain that all connections are secure.

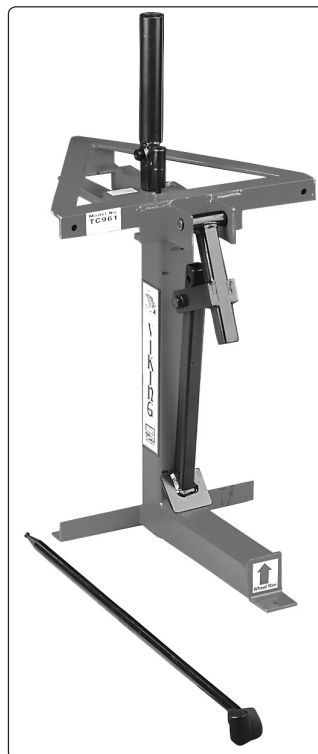

**TC961**



**TC962**

## 4. OPERATION - TC961

The **TC961** Tyre Changer is manually operated - no air supply is required. It is designed for removing/fitting tyres from/to most sizes of open-centre wheels (see Section 3 Specifications). Do not use the tyre changer for any other purpose.

If tyres are to be changed on aluminium wheels the optional tyre bar, Sealey model no. **TC963**, must be used to prevent damage to the wheel rims.

**IMPORTANT! Never attempt to fit or remove a tyre without first lubricating both beads.**

### 4.1. Bead breaking

- 4.1.1. Deflate the tyre and remove all balance weights.
- 4.1.2. Lift the bead breaker clear of the tyre changer foot.
- 4.1.3. Place the wheel on the foot of the tyre changer, locating the rim as indicated. Position the bead breaker spade under the rim flange (fig. 1).
- 4.1.4. Put the tyre bar into the bead breaker socket.
- 4.1.5. Pull down firmly on the bar and repeat around the rim until the bead is free.
- 4.1.6. Turn wheel over and repeat to free the other bead.

**Note:** When bead breaking on TD or TDX wheels the wheel **must be horizontal**. Locate the rim on the foot of the tyre changer and support the opposite side of the wheel with a suitable piece of timber.

### 4.2. Tyre removal

- 4.2.1. Lubricate both tyre beads with an approved rubber lubricant.
- 4.2.2. Remove the wheel retaining sleeve from the centre post.
- 4.2.3. Place the wheel onto the stand **with the narrow bead seat uppermost**.
- 4.2.4. Replace the wheel locating clamp onto the centre post (fig. 2), inserting the wheel peg into one of the wheel mounting holes.
- 4.2.5. Turn the wheel clockwise on the stand until it locks.
- 4.2.6. Insert the ball end of the tyre bar beneath the top bead and press the opposite side of the bead down into the wheel well.
- 4.2.7. Lever the bar against the wheel location clamp and rotate the bead over the rim (fig. 3).
- 4.2.8. If a tube is fitted, tighten the locating clamp thumb screw to prevent wheel lifting and then pull out the tube.
- 4.2.9. Lift the tyre up and repeat the procedure for the lower bead.

### 4.3. Tyre fitting

- 4.3.1. Lubricate both tyre beads with an approved rubber lubricant.
- 4.3.2. Mount and lock the wheel to the stand as in 4.2.2. to 4.2.5.
- 4.3.3. Place the lower bead of the tyre over the wheel rim and insert the fitting head of the tyre bar between the bead and the rim with the bead on the ledge of the fitting head.
- 4.3.4. Lever the bar against the wheel location clamp and rotate the bead over the rim (fig. 4).
- 4.3.5. Fit a tube if appropriate and then seat the upper bead in the same manner.

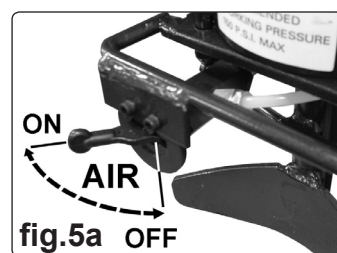
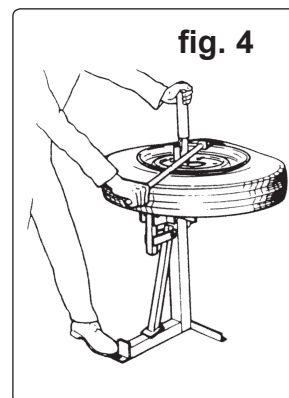
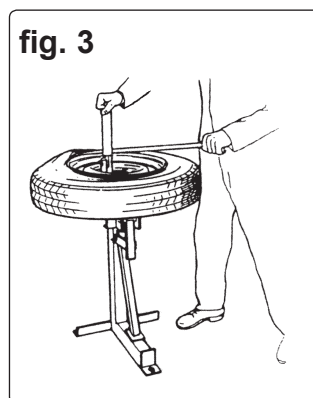
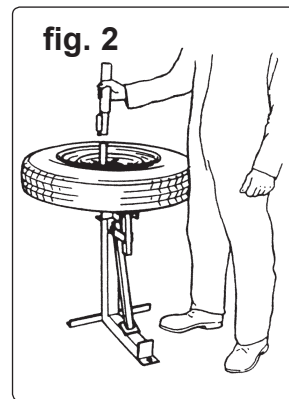
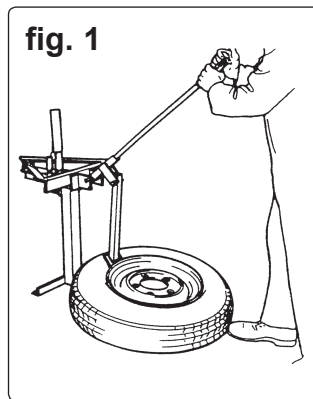

## 5. OPERATION - TC962

The **TC962** Tyre Changer is air assisted. It is designed for removing/fitting tyres from/to most sizes of open-centre wheels (see Section 3 Specifications). Do not use the tyre changer for any other purpose. **Alloy Wheels.** If tyres are to be changed on aluminium wheels the optional tyre bar, Sealey model no. **TC963**, must be used to prevent damage to the wheel rims (See fig.5b). Use a rim shield to protect the wheel finish when levering a bead over the wheel rim.

**IMPORTANT! Never attempt to fit or remove a tyre without first lubricating both beads.**

### 5.1. Bead breaking (For 18" wheels refer to section 5.4)

- 5.1.1. Deflate the tyre and remove all balance weights.
- 5.1.2. Place the wheel under the bead breaker, locating the rim as indicated. Position the bead breaker ram so that the spade is under the rim flange (fig. 5).

**Note:** Before operating breaker place one foot on the wheel, opposite the spade, to prevent wheel 'kick-up'.

- 5.1.3. Open the air valve slightly (See fig.5a) to lower the spade - **do not** use full pressure. Check that the spade is firmly set on the tyre bead, close to the rim and then increase the pressure gradually until the bead breaks free.
- 5.1.4. Rotate the wheel and repeat around the rim until the whole bead is free.
- 5.1.5. Turn wheel over and repeat to free the other bead.

**Note:** When bead breaking on TD or TDX wheels the wheel **must be horizontal**. Locate the rim on the foot of the tyre changer and support the opposite side of the wheel with a suitable piece of timber.

### 5.2. Tyre removal

- 5.2.1. Lubricate both tyre beads with an approved rubber lubricant.
- 5.2.2. Remove the wheel retaining cone from the centre post.
- 5.2.3. Place the wheel onto the rubber mat on the stand **with the narrow bead seat uppermost**.
- 5.2.4. Replace cone over centre post and fit locating pin through post and both sides of cone tube. (Precautions should be taken to protect the finish of an alloy wheel from the pressure exerted by the cone)
- 5.2.5. Activate the bead breaker - this will pull down the centre post and so clamp the wheel.

**WARNING!** Make sure that feet and legs are clear of the spade when carrying out this operation.

- 5.2.6. Insert the ball end of the tyre bar beneath the top bead and press the opposite side of the bead down into the wheel well.

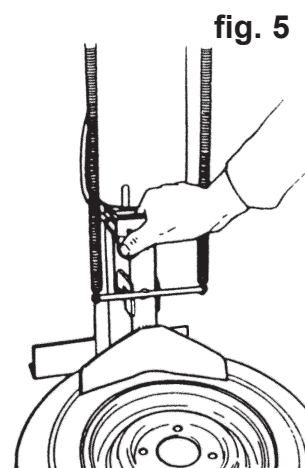

Tyre bar TC963 for alloy wheels (Optional)

5.2.7. Lever the bar against the cone tube and rotate the bead over the rim (fig. 6).

5.2.8. If a tube is fitted, remove it.

5.2.9. Lift the tyre up and repeat the procedure for the lower bead.

### 5.3. Tyre fitting

5.3.1. Lubricate both tyre beads with an approved rubber lubricant.

5.3.2. Mount and lock the wheel to the stand as in 5.2.2. to 5.2.5.

5.3.3. Place the lower bead of the tyre over the wheel rim and insert the fitting head of the tyre bar between the bead and the rim with the bead on the ledge of the fitting head.

5.3.4. Lever the bar against the cone tube and rotate the bead over the rim (fig. 7).

5.3.5. Fit a tube if appropriate and then seat the upper bead in the same manner.

fig. 6

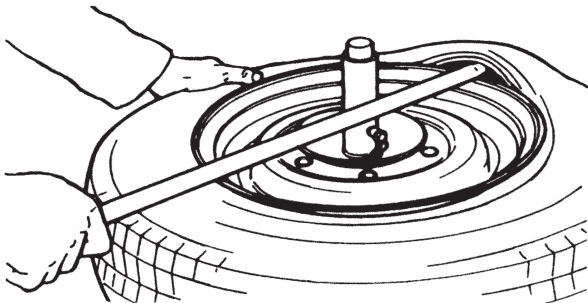
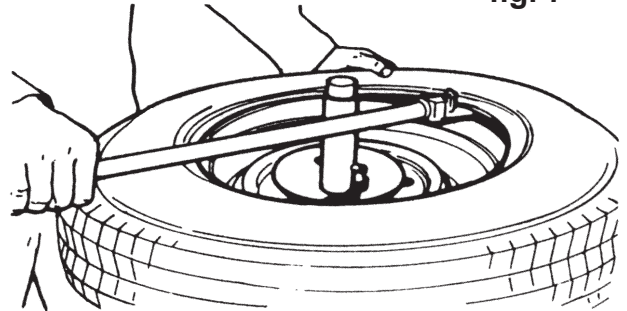

fig. 7



### 5.4 BEAD BREAKING ON 18" WHEELS.

With an 18" wheel resting on the tyre changer foot there is insufficient clearance at 'X' in fig.8 to access the tyre bead. To remedy this situation refer to fig.9. Butt the tyre up against the end of the tyre changer foot as shown at 'B' in fig.9. Take hold of the handle on the ram mechanism and pull it away from the main support so it is at an angle as shown at 'A' with the spade close to the bead. **Note:** Before operating breaker place one foot on the wheel, opposite the spade, to prevent wheel 'kick-up'. Position the bead breaker ram so that the spade is under the rim flange. Open the air valve slightly to lower the spade - **do not** use full pressure. Check that the spade is firmly set on the tyre bead, close to the rim and then increase the pressure until the bead breaks free. To proceed refer back to section 5.1.4.

fig. 8

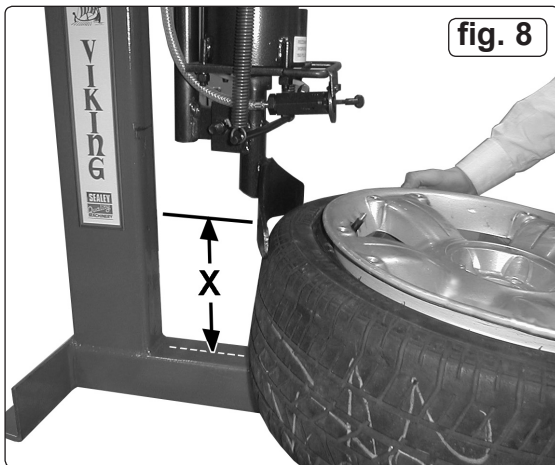

INCORRECT POSITIONING FOR 18" WHEEL

fig. 9

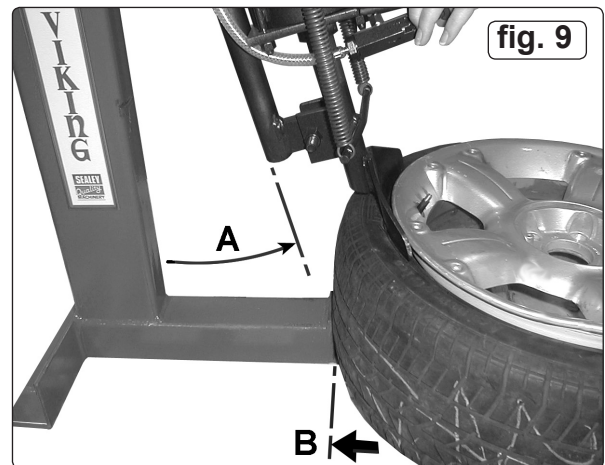

CORRECT POSITIONING FOR 18" WHEEL

**NOTE:** It is our policy to continually improve products and as such we reserve the right to alter data, specifications and component parts without prior notice.

**IMPORTANT:** No liability is accepted for incorrect use of this product.

**WARRANTY:** Guarantee is 12 months from purchase date, proof of which will be required for any claim.

**INFORMATION:** For a copy of our latest catalogue and promotions call us on 01284 757525 and leave your full name and address, including postcode.



Sole UK Distributor, Sealey Group,  
Kempson Way, Suffolk Business Park,  
Bury St. Edmunds, Suffolk,  
IP32 7AR

01284 757500

01284 703534

www.sealey.co.uk

sales@sealey.co.uk

TC961

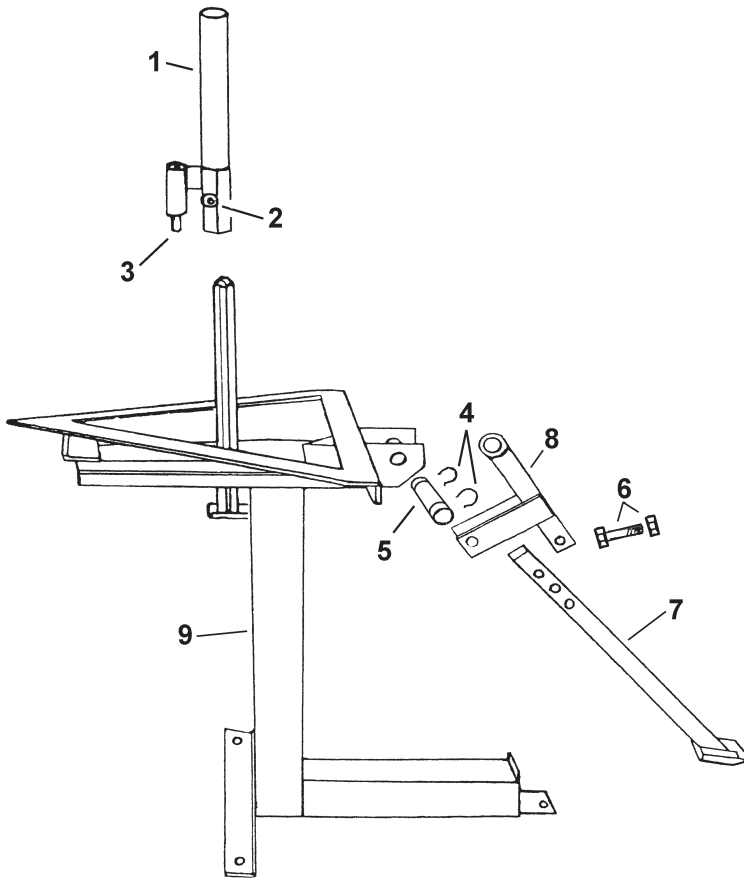

TC962

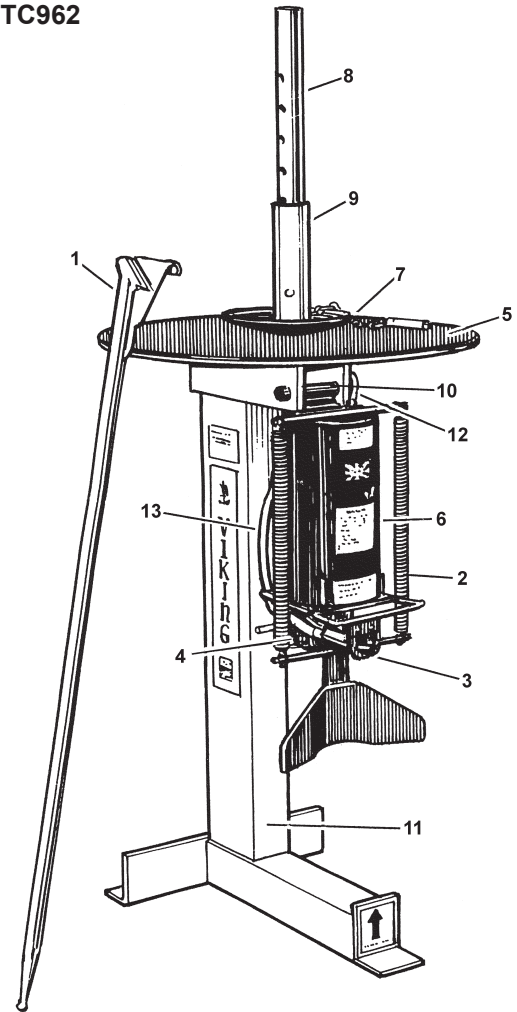

Item	Part No.	Description
-	363/348	Bar, Tyre Fitting/Removing (not shown)
1	363/CE23-1	Wheel Locating Clamp, Thumb
		Screw & Wheel Peg
2	363/CE23-2	Screw, Thumb
3	363/CE23-3	Peg, Wheel
4	363/CE23-4	Circlip
5	363/CE23-5	Pin, Bead Breaker
6	363/CE23-6	Nut & Bolt, Bead Breaker
7	363/CE23-7	Breaker, Bead
8	363/CE23-8	Support, Bead Breaker
9	363/CE23-9	Frame, Main

Not supplied with Tyre Changer  
 - TC963 Tyre Bar, Aluminium Wheels

Item	Part No.	Description
1	363/348	Bar, Tyre Fitting/Removing
2	363/378	Spring, Return
3	363/379	Lever, Valve
4	363/380	Valve, Control
5	363/400	Mat, Rubber
6	363/402	Ram Assembly Complete
7	363/452	Pin & Chain
8	363/455	Post, Centre
9	363/456	Clamp Assembly, Wheel
10	363/457	Pin & Circlip, Ram
11	363/458	Frame
12	363/459	Hose, Air
13	363/460	Hose, Air, Ram

Not supplied with Tyre Changer  
 - 363/483 Seal Kit, Ram  
 - TC963 Tyre Bar, Aluminium Wheels

Version No: 1  
 Date Issued: 180701